



WIN G&D

Winterthur Gas & Diesel

Modern Engine Technologie in China

CIMAC circle at Marinetec Shanghai, 7. December 2017

Status

WinGD's involvement so far

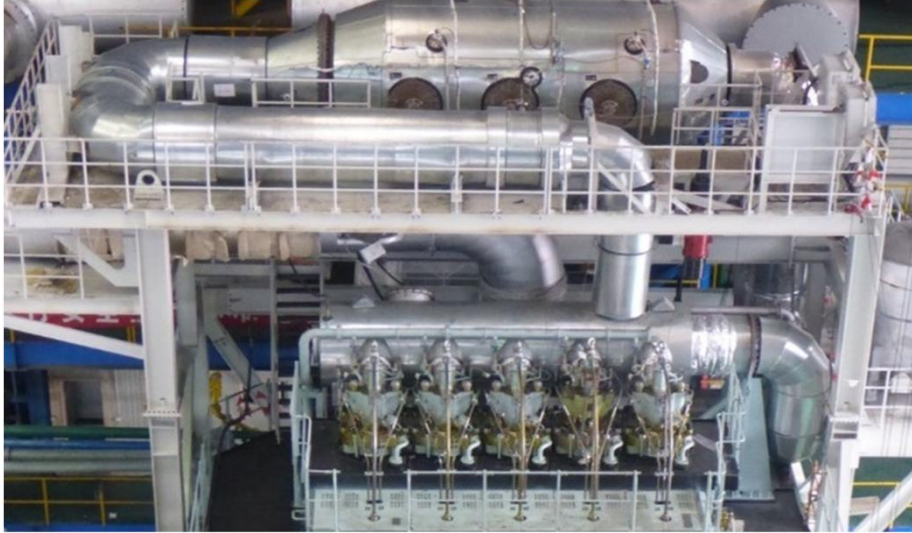

HP-SCR @ CMD



Terntank vessel, pictures courtesy of Avic



QMD works

Current technology enhancements

Gaseous emissions control

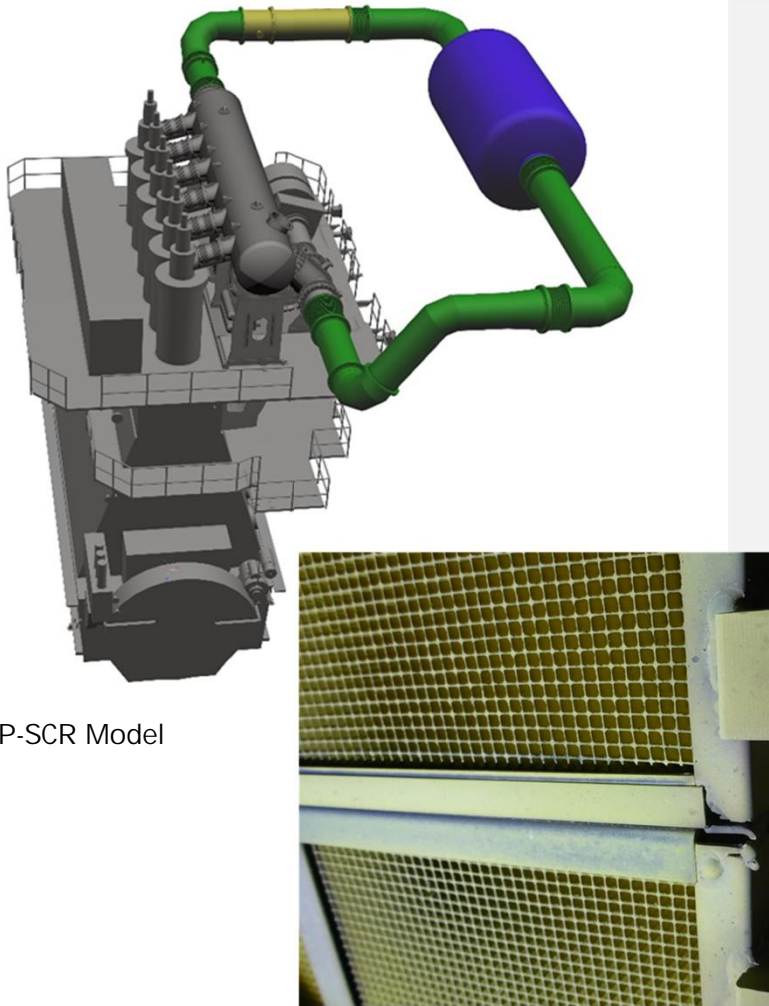

HP-SCR Model

Catalysts

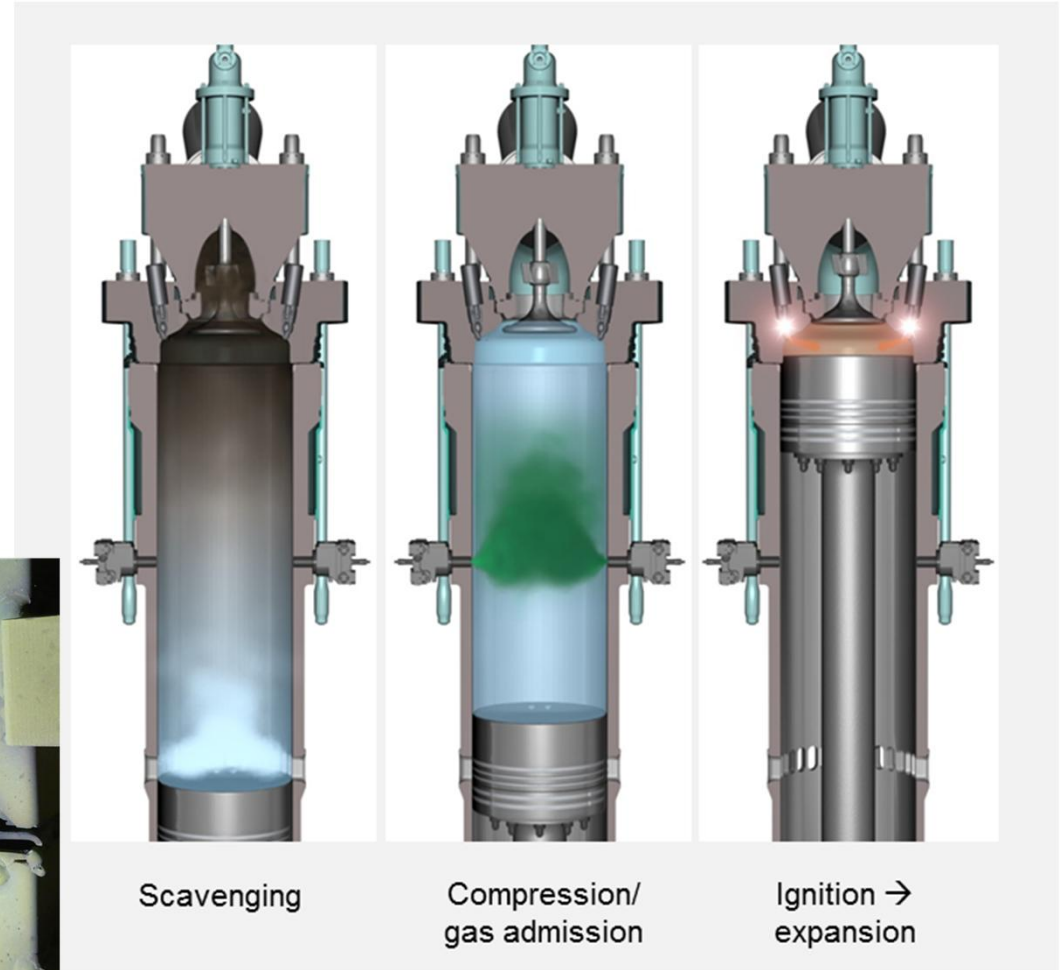

'Pre-mixed lean-burn' combustion



Future technologies

Orchestrated developments...?

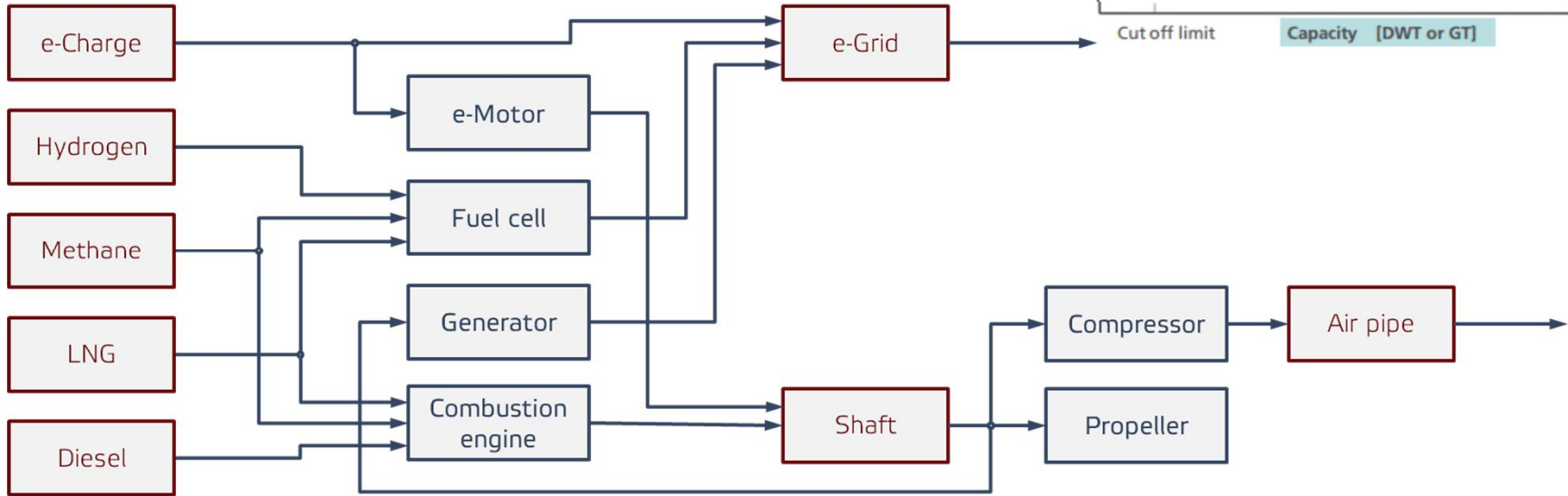
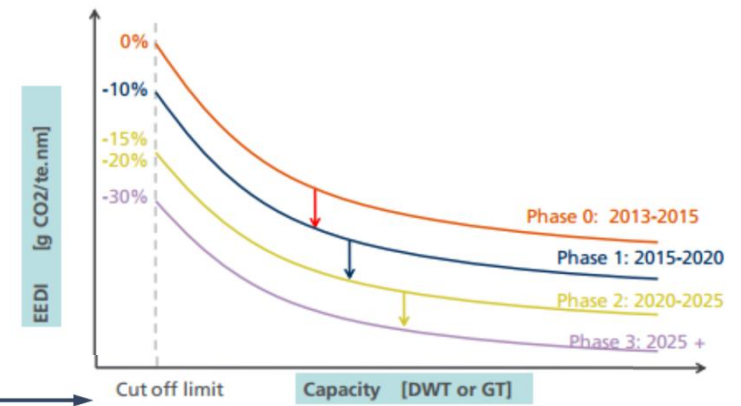

Future energy conversion possibilities on board, simplified and incomplete



image: www.leclanche.com



image: www.norwegianelectric.com

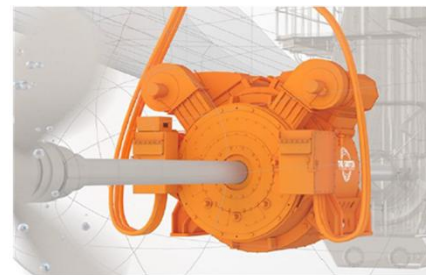

image: www.theswitch.com

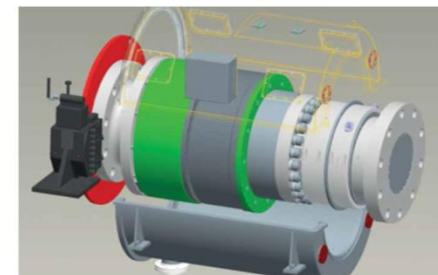

image: renk

